

**POWERS****A WATTS INDUSTRIES CO.****SINGLE SEAT BRONZE BODY**

- ▶ 1/2", 3/4", 1", 1-1/4", 1-1/2", and 2" Screwed NPT Ends
- ▶ ANSI Class 250 Body Rating
- ▶ ANSI Class IV Close off
- ▶ Hardened 17-4 Stainless Steel Trim
- ▶ Top and Bottom Stem Guided
- ▶ Equal Percent Flow Characteristic
- ▶ 46" Pneumatic Diaphragm, Field Reversible Actuators
- ▶ Stainless Steel Hardware
- ▶ Mounted Standard Yoke for Accessories

DESCRIPTION

The rugged Powers Type SS (single seat bronze body) valve is primarily used for steam and water modulating applications. It has greater pressure drop capabilities than all other Powers bronze body valves. The equal percent plug provides excellent control characteristics and is more

tolerant of oversizing than linear or quick-opening plugs. The standard hardened 17-4 stainless trim provides long life and is recommended for all applications over 50 PSI. The SS's control close-off and wear characteristics are particularly well-suited to industrial applications.

DIMENSIONAL INFORMATION (For other sizes consult factory)

Pneumatic Diaphragm Actuators

Actuator*	A	B	lbs.
46"	10"	10-3/8"	14

Valve Body

Size	C	D	E	lbs.
1/2	2-13/18"	1-11/16"	2-1/2"	2.5
3/4 & 1	3-7/8"	2-3/4"	2-7/8"	5
1-1/4	5-1/16"	3-7/8"	3-13/16"	10
1-1/2	5-1/16"	3-7/8"	3-13/16"	10.5
2	6-3/16"	3-1/4"	3-7/8"	15.5

PNEUMATIC DIAPHRAGM ACTUATOR

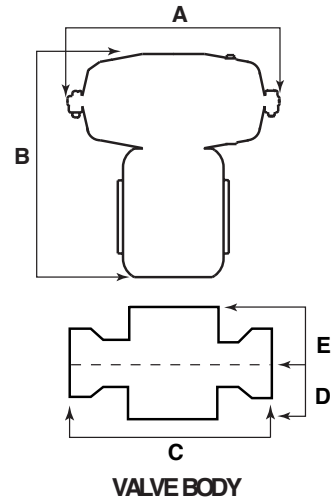

APPLICATION

To properly size a valve either follow these criteria or use the PowerSize® valve sizing program available at www.powerscontrols.com.

- **Body Material and Rating.** Bronze ANSI Class 250 Body with screwed NPT ends, 1/2" through 2". Refer to Body Temperature/ Pressure Ratings table to insure your application fits in the acceptable operating range. Also determine that the valve body material is compatible with your media.
- **Trim Material.** Hardened 17-4 stainless steel with replaceable seat.
- **Flow Coefficient (CV Rating).** Refer to PowerSize Valve Sizing Program or specifying engineer's data to determine Cv. Select a valve size that most closely matches the calculated Cv from the Flowing ΔP, Close Off ΔP, and Cv Ratings table.
- **Flowing Pressure Drop (ΔP).** To avoid cavitation and its accompanying trim damage, the following operating ΔP limits should be observed.

BODY TEMPERATURE/ PRESSURE RATINGS

ANSI Standard Ratings— Bronze Bodies

Temperature (°F)	Class 250 Lb. (psig)
-20 to 150	400
200	385
250	365
300	335
350	300
400	250

- **Liquid Service.** ΔP less than the quantity $(0.66 \times \text{inlet pressure}) + 10$. Additionally, flowing ΔP should not exceed 100 PSI.
- **Steam Service.** ΔP less than the quantity $(0.5 \times \text{inlet pressure}) + 7.35$. Additionally, flowing ΔP should not exceed 100 PSI.
- **Actuator Selection.** The actuator must have enough force to close off against line pressure or maximum ΔP.

The 3–15 and 1–17 columns in the Close Off ΔP and Cv Ratings table apply to valves with control signals coming directly from I/P transducers. The 0–30 column applies to valves using Accritem® type pneumatic controllers or valves equipped with a positioner or 0–30 PSI I/P transducer. If your ΔP exceeds the value in the table, it will be necessary to evaluate the use of an in-line shutoff valve or alternate control valve meeting your close-off ΔP requirements.

Type SS CLOSE OFF ΔP AND CV RATINGS

Valve Size	CV Rating	Plug Travel	Actuator Codes	Maximum ΔP in PSI at Close Off					
				Fail Closed			Fail Open		
				Signal to Actuator			Signal to Actuator		
				Pneumatic			Pneumatic		
3-15 PSI	1-17 PSI	0-30 PSI	3-15 PSI	1-17 PSI	0-30 PSI				
1/2	27	3/4	46/ 4C	200	200	200	200	200	200
			4X	-	200	200	-	200	200
3/4	6	3/4	46/ 4C	137	200	200	137	200	200
			4X	-	78	200	-	200	200
1	10	3/4	46/ 4C	57	200	200	57	200	200
			4X	-	24	200	-	152	200
1-1/4	16	1	46/ 4C	-	68	200	53	192	200
			4X	-	-	200	-	-	200
1-1/2	20	1	46/ 4C	-	37	135	27	124	200
			4X	-	-	200	-	-	200
2	38	1	46/ 4C	-	11	66	5	60	200
			4X	-	-	127	-	-	135

NOTES: 1) A 200 PSI ΔP limit is imposed for trim life considerations
 2) Close off pressures can be substantially increased on the 46" diaphragm actuators by sacrificing full stroke capability for cases where total valve capacity is not required. There is no way to publish formulas for all possible combinations. Rule of thumb is that, generally, close off pressures listed in the 0-30 PSI column are possible with a 3-15 PSI control signal by adjusting preload to compromise full stroke.

SIZING REFERENCE

STEAM TABLE

Steam Pressure PSIG	Temp. °F	Temp. °C	Sensible Heat BTU/lb.	Latent Heat BTU/lb.	Total Heat BTU/lb.
0	212	100	180	971	1151
10	239	115	207	952	1159
25	266	130	236	934	1170
50	297	147	267	912	1179
75	320	160	290	896	1186
100	338	170	309	881	1190
125	353	178	325	868	1193
150	365	185	339	858	1197
200	387	197	362	838	1200
250	406	208	381	821	1202
300	422	217	399	805	1204
400	448	231	438	778	1216
500	470	243	453	752	1205
600	489	254	475	729	1204

LOAD SIZING CALCULATIONS

Heating Water with Steam

Quick Method

$$\text{Lbs. / hr.} = \frac{\text{GPM}}{2} \times \Delta T$$

Precise Method

$$\text{Lbs. / hr.} = \frac{\text{GPM} \times 500 \times \Delta T}{h_g}$$

Heating or Cooling Water with Water

$$\text{GPM}_1 = \text{GPM}_2 \times \frac{\text{°F water}_2 \text{ temp rise or drop}}{\text{°F water}_1 \text{ temp rise or drop}}$$

Heating or Cooling Water

$$\text{GPM} = \frac{\text{BTU/hr.}}{(\text{°F water temp. rise or drop}) \times 500}$$

Heating Oil with Steam

$$\text{Lbs. / hr.} = \frac{\text{GPM}}{4} \times (\text{°F oil temp. rise})$$

GLOSSARY OF TERMS

- t = Time in hours
- Cp = Specific Heat of Liquid
- S = Specific Gravity of Fluid
- W = Weight in lbs
- ΔT = Temperature rise or fall in °F
- h_g = Latent Heat of Steam

RECTANGULAR TANK CAPACITY IN GALLONS

$$\text{Gallons} = \frac{\text{Height} \times \text{Width} \times \text{Length (inches)}}{230}$$

$$\text{Gallons} = \text{H} \times \text{W} \times \text{L (ft.)} \times 7.5$$

CIRCULAR TANK STORAGE CAPACITY IN GALLONS

$$\text{Storage} = 6.3 \times L (\text{Gallons})$$

Where: D = tank diameter in Feet

L = length in Feet

Heating Air with Water

$$\text{GPM} = 2.16 \times \frac{\text{CFM} \times (\text{°F air temp. rise})}{1000 \times (\text{°F water temp drop or rise})}$$

Heating Liquids with Steam

$$\text{Lbs. / hr.} = \frac{\text{GPM} \times 60 \times \text{CP} \times \text{W}}{h_g} \times \Delta T$$

Heating Liquids in Steam Jacketed Kettles

$$\text{Lbs. / hr.} = \frac{\text{GPM} \times \text{Cp} \times \text{S} \times 8.33}{h_g \times t} \times \Delta T$$

General Liquid Heating

$$\text{Lbs. / hr.} = \frac{\text{W} \times \text{Cp}}{h_g \times t} \times \Delta T$$

Heating Air with Steam

$$\text{Lbs. / hr.} = \frac{\text{CFM}}{900} \times \Delta T$$

CONVERSION FACTORS

- 1 lb. Steam/ Hr. = 1000 BTU/Hr
- 1 Cubic Meter = 265 US Gallons
- 1 Cubic Foot Water = 62.4 lbs
- 1 PSI = 2.04 inches of Mercury
- 1 PSI = 2.3 feet of Water
- 1 PSI = 27.7 inches of Water
- 1 U.S. Gallon Water = 231 Cubic inches
- 1 U.S. Gallon Water = 8.33 lbs

ORDERING INFORMATION

593- **S** **S** **S** **S**

Size	Order Code
1/2'	050
3/4'	075
1"	100
1-1/4"	125
1-1/2'	150
2'	200

End Connections
 Stewed S

Valve Trim
 Stainless S

Action
 Fail Open (Air to Close) X
 Fail Closed (Air to Open) C

Packing
 Teflon V Ring S
 EPDM Ring W

**ACCESSORIES
 SELECT CODE**
 (see page 6)

**ACTUATOR
 SELECT CODE**
 (see below)

ACTUATOR SELECT CODE

CODE	PNEUMATIC DIAPHRAGM ACTUATORS
46	46 Sq. In., 1" Max Valve Stroke with Standard Springs adjustable stat w/ 7~12 lb. Fixed span
4X	46 Sq. In., 1" Max Valve Stroke with Extended Range Springs (requires positioner), adjustable stat w/ 22 lb. span
4C	46 Sq. In., 1" Max Valve Stroke with Extreme Cycle Springs adjustable stat w/ 7~12 lb. Fixed span

ORDERING INFORMATION (cont'd)**ACCESSORIES SELECT CODE**

BELLOFRAM 1000 I/ P S		UTILITY POSITIONER AND I/ P		NO ACCESSORIES	
<u>Code</u>	<u>Description</u>	<u>Code</u>	<u>Description</u>	<u>Code</u>	<u>Description</u>
IS	3-15 psi	ES	4-20 mA	OS	No accessories
TS	1-17 psi	UTILITY POSITIONER			
US	3-27 psi	<u>Code</u>	<u>Description</u>		
CONTROL/ AIR TYPE 900X I/ P		FS	3-15 psi		
<u>Code</u>	<u>Description</u>	FB	3-9 psi		
ES	0-30 psi	SS	9-15 psi		

I/ P TRANSDUCERS

The "standard" 3-15 psi signal was originally designed as a transmission signal, not a valve actuation signal. Unbalanced control valves have their operational limits lowered when forced to operate with this 3-15 psi signal. The Fluid Controls Institute (in Standard 87-2) has recommended that a 1-17 psi air signal range be used when directly actuating a control valve without a positioner. Powers concurs with this recommendation, and therefore, offers a 1-17 psi I/P transducer and a 0-30 psi I/P transducer for maximum close-off. 3-15 psi I/P transducers should be used in conjunction with positioners.

POSITIONERS

Positioners are used for one or more of the following reasons:

- 1) To split range valves.
- 2) To eliminate unwanted valve movement caused by line pressure variations
- 3) To minimize the effects of "stick-slip"
- 4) To speed response time and/or
- 5) To increase close-off rating when I/Ps are used.

CALCULATION SKETCH AREA

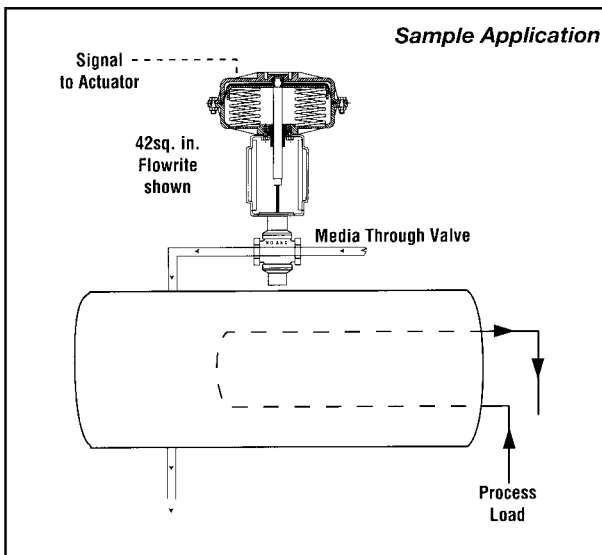

- Considerations: _____
- _____
- _____
- _____
- Medium: _____
- Capacity: _____
- Inlet Pressures: _____
- Pressure Drop: _____
- Temp.: (Packing): _____
- Fail Safe: _____

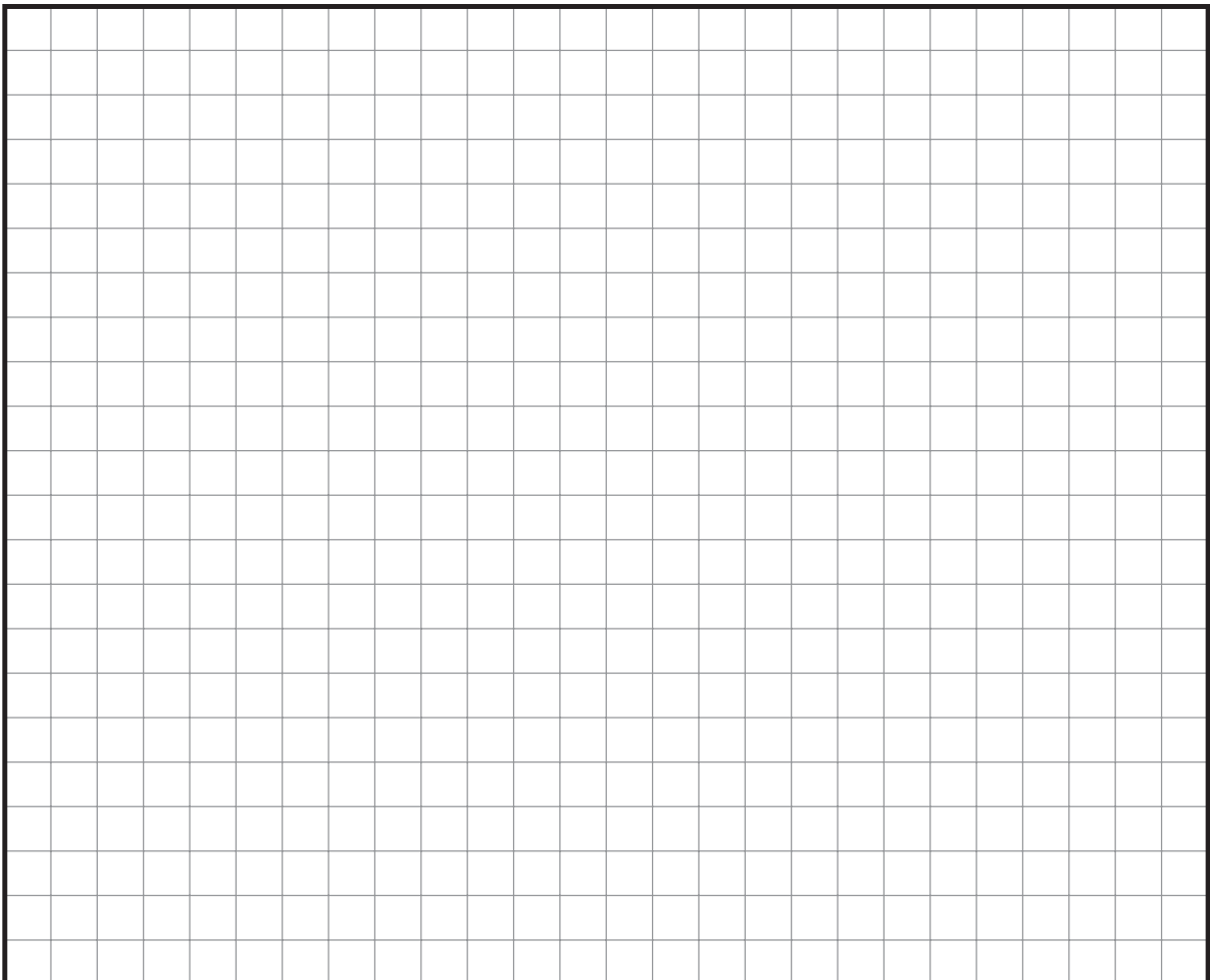

Mountain Controls



COPPUS®
Air Movers

Portable Ventilators
Fans & Blowers
Welding Fume Exhausters
Mist Coolers & Duct



A-T Controls, Inc.

Ball Valves and Actuators
Spring Return Electric Actuators
Resilient Seated Butterfly Valves
High Performance Butterfly Valves



MARSH®

Pressure Gauges
Thermometers
Needle Valves and Diaphragm Seals



BELLOFRAM
Precision Controls

Precision Air Regulators
Air, Gas, Steam & Water Regulators
Vacuum and Backpressure Regulators
I/P and E/P Transducers

BelGAS

Temperature Indicators
Temperature Switches
Capillary Bulb Type

Marshalltown-Tempco

MOORE INDUSTRIES
WORLDWIDE

Process Controllers
Multi-Loop
Process Indicators with Switches

POWERS PROCESS CONTROLS
Quality...Our Commitment

Control Valves – Globe Type
Temperature Regulators
Self Contained
Temperature Controllers

RCS

Electric Actuators
Modulating Controllers
Spring Return – SURE
Mounting to your valves.

SVF
Flow Controls, Inc.

Ball Valves – 3-piece
Pneumatic Actuators
Electric Actuators
Specialty Valves

G C
VALVES

Solenoid Valves
Water – Air – Hot Water – Steam
Pilot Valves

Valve Actuator Mounting

We stock electric actuators and can provide the mounting and testing to the valve of your choice

Mountain Controls

Mail: mountaincontrolsinc@gmail.com Web: www.mountaincontrols.com
Phone: 801-487-8795 Fax: 801-487-8798
Salt Lake City, UT 84109