

Type 3512 & 3522

Digital Weatherproof Regulators

Description

The Type 3512 single loop and 3522 double loop are single units - integrated controller and booster. The 3512/3522 offers solenoid valve technology with forward flow exceeding those of most standard industrial electronic regulators or I/P transducers. Available with a local keypad programming option or RS-485 digital communications for PLC or PC control. Many output pressure ranges are available up to 150 PSI. With a reliable twin solenoid valve system, and an integral pressure sensor, an accuracy of $\pm 0.5\%$ is obtainable.

Applications include; Gripper Control, Welding Operations, Actuator Control, Machinery Automation, Precision Robotics, Web Tension, Semiconductor Equipment, Molding and Forming Operations and Tire Manufacturing and Testing.

Features

- Serial Interface
- Digital or Analog Inputs
- Analog Monitor Output
- Single Loop and Dual Loop Control
- Forward Flow up to 60 SCFM
- Digital Display

Type 3512 and 3522 Ordering Information

5	2	0	P	1	
↑	↑	↑	↑	↑	Loops
1					1 loop
2					2 loops
2					
					Digital Interface
	S				Serial RS-485 (RS-232 and USB via converters)
	P				Keypad/display programmer
					Analog Control Signal
		E			0-10V
		I			4-20 mA
					Lower Output Pressure
		O			Lower Limit of Output Pressure
					Pressure Units
			G		PSIG
					Upper Output Pressure
		030			30 PSIG
		100			100 PSIG
		150			150 PSIG Upper Limit
					Mounting
			P		Pipe Mount
					Supply and Output Ports
				0	1/4 NPT
				1	1/4 BSPT
				2	1/4 BSPP
				3	3/8 NPT
				4	3/8 BSPT
				5	3/8 BSPP
					Options
					00 None
					15 15 VDC Supply



Type 3512/3522

Performance	Full-Scale Accuracy 0.5%	
Electrical Inputs		
Supply Voltage	24VDC (optional 15VDC)	
Stand by Supply Current	80 mA	
Maximum Supply Current	325 mA	
Supply Pressure	Max. Output PSIG (BAR)	Max. Supply PSIG (BAR)
	Up to 5 (.35)	20 (1.4)
	>5 to 15 (.35-1.0)	30 (2.1)
	>15 to 30 (1.0-2.1)	60 (4.1)
	> 30 to 100 (2.1-6.9)	165 (11.4)
	>100 to 150 (6.9-10.3)	200 (13.8)
Outputs		
Atmospheric Pressure Ranges	30, 100, 150 PSIG 0.35, 1.03, 2.07, 6.9, 10.34 BAR	
Forward Flow Capacity	60 SCFM (1700 LPM)	
Exhaust Flow Capacity	15 SCFM (425 LPM)	
Analog Setpoint Control	0-5V, 0-10V, 4-20mA	
Digital Setpoint Control	0-100% full scale (installed sensor=100%)	
Digital Communications	Serial RS-485 interface	
Serial Address	Addresses a-z available (except p and q reserved). 'r' default selectable and configurable via Serial or Keypad Display Interface	
Loop Options	Regulate first loop (onboard sensor) or 2nd loop (remote sensor)	
Remote Sensor Feedback	0-10V, 0-5V, 4-20 mA, (Forward and Reverse Acting)	
Analog Output Source	Follow Setpoint, Output Pressure, or Remote Sensor	
Analog Output Range	0-10V, 0-5V	
Environmental		
Operating Temperature	32-141°F (0-60°C)	
Media-Wetted Materials	Aluminum, copper alloys, nickel, buna-n, silicon, 316SS	

Type 3000

Comparison of I/P's

Type 3000 Series Comparison Chart

T1000, T1500, T1001 and T2000	T3000 Series
Steady Air Consumption	Minimal Air Consumption at Steady State
Many are Loop Powered	All Require Supply Voltage
Most Available in Intrinsically Safe or Explosion Proof Versions	No Hazardous Area Approvals
"Standard" Pressure Range to 120 PSI, No Vacuum Models, Limited Low Pressure Control Capability	Wide variety to 600 psi or vacuum, even possible in 0 to 0.2 psi range
Downstream Sensor Feedback Not Available	Second Loop Feedback Available
	Analog and Logic Output Signal Monitoring
	Digital Versions have Keypad or Serial User Interface
	Wide Range of Input Signal/Output Pressure Endpoint, Available in Digital

Air Quality

Bellofram specifies the use of instrument quality air (clean, dry, oil free) for all transducers. Transducers should be used within the following conditions:

- Dew Point < 35°F (2°C) (indoor)
- Oil Content < 1ppm
- Particles < 3µm.

The use of filters in the supply air system is highly recommended. Contact us for information on our filters and filter regulators.

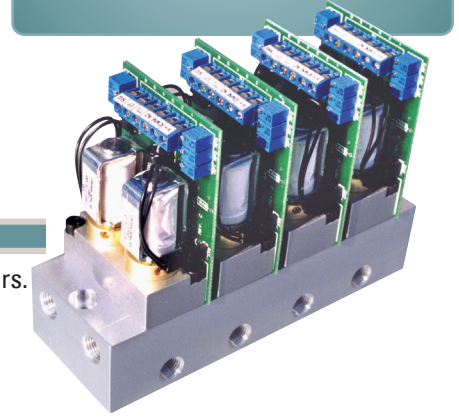
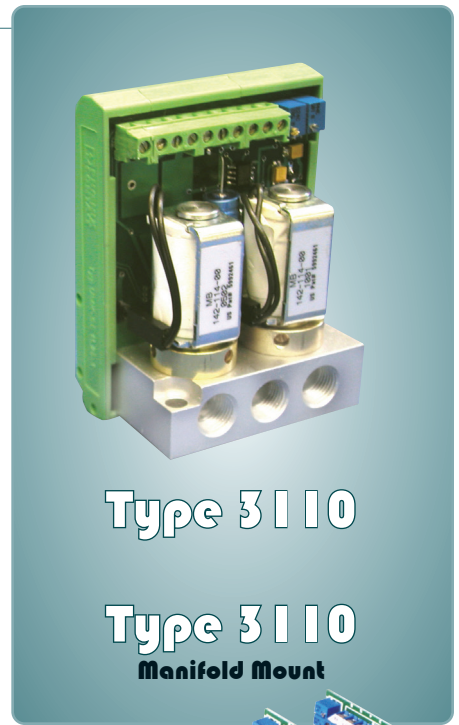

Type 3000 Series Electro-Pneumatic Transducers

		Packaging				
		DIN-mount Circuit Card	Weatherproof Enclosure			
			Low Flow (1.2 SCFM) (34 LPM)	Low Flow (1.2 SCFM) (34 LPM)	Medium Flow (15 SCFM) (425 LPM)	High Flow (60 SCFM) (1700 LPM)
User Interface	Analog 0-10V 4-20mA	T3110, T3120 or T3111	T3210 or T3220	T3211, T3221 or T3311	T3212 or T3222	T3215
	Serial RS-485, RS-232, USB	T3410S or T3420S	T3510S or T3520S	T3511S or T3521S	T3512S or T3522S	
	Keypad/Display Programmer	N/A	T3510P or T3520P	T3511P or T3521P	T3512P or T3522P	
Mounting		DIN tray, manifold, panel	In-line, DIN-rail, panel bracket, or manifold	In-line, DIN-rail, panel bracket, or manifold	In-line, DIN-rail, panel bracket, or manifold	In-line or panel bracket

Type 3000 Series

Overview

Features and Capabilities

The Type 3000 series of electro-pneumatic transducers offers an innovative set of features and capabilities. Each electronic pressure regulator utilizes a pair of reliable quick-firing solenoid valves and an onboard pressure sensor to precisely control downstream pressure and at the same time achieve excellent accuracy and stability.

Feed-and-bleed transducers are inherently resistant to shock, vibration, and orientation. To size the regulator for the application, a selection of external volume boosters up to 2000 SCFM (56,000 lpm) are available.

- Analog Control Signals: 0-10v, 4-20 mA, etc.
- Remote Sensor Feedback
- Monitor Output
- High/Low Logic Output
- Digital Signal Processing
- PID Tuning
- Deadband Adjustment
- Serial, Keypad/Display

Theory of Operation

T3000 transducers utilize proven feed-and-bleed technology. The Supply Solenoid Valve feeds supply pressure to the downstream application. The Exhaust Solenoid Valve bleeds off overpressure. By monitoring the onboard pressure sensor (or the user-supplied remote sensor on two-loop units), the electronics rapidly fire one solenoid or the other to maintain the desired setpoint.

Standard Type 3000s hold output pressure upon loss of electrical power, as long as there are no downstream flow demands. Special versions are available for Fail High or Low Operation.

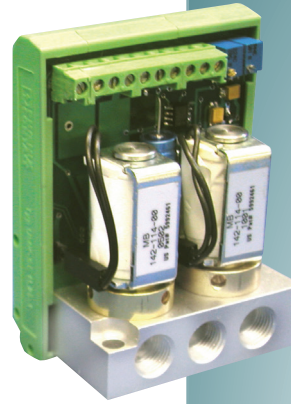

Type 3110

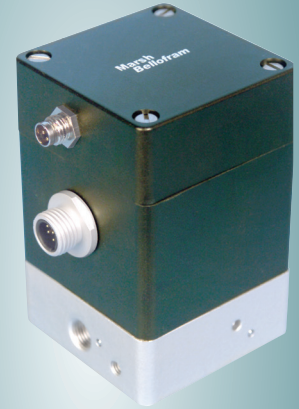

Type 3210



Type 3211

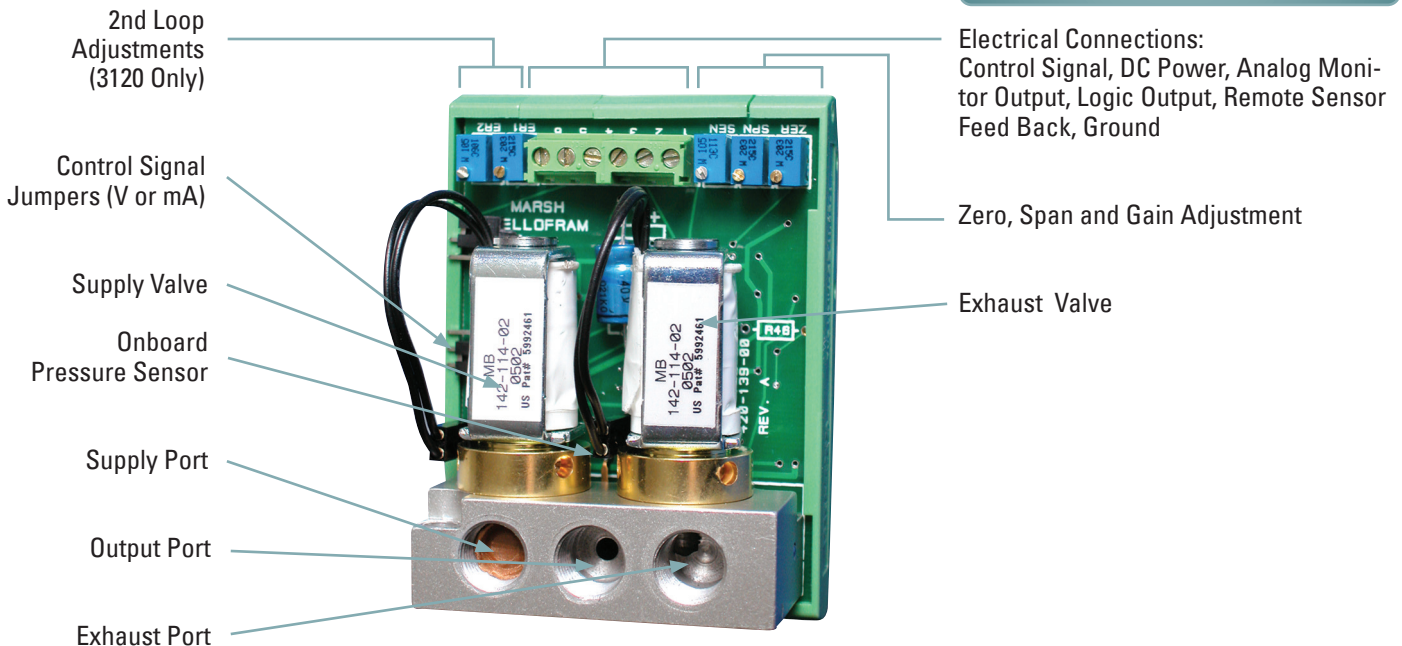

Digital Electro-Pneumatic Transducers

Features

Multiple User Interfaces

(See examples on these pages)

- Analog interface (mA or voltage signal)
- Serial RS-485 (RS-232 and USB via converters) — use our program or write your own, as several high tech customers have done!
Control up to 24 addressable units on an RS485 link. The serial link permits customizing the factory settings to your needs.
- Keypad /display: easily configure the transducer to your needs

Input and Output Settings

With keypad or serial communications, you can set almost any low and high end points (input/output points) within the range of the selected sensor. You are not limited to points on a linear zero to maximum span I/O plot as on other I/Ps and E/Ps. *(For example, if your primary process settings require an output of 25 PSI at 2 volts signal and 50 PSI at 8.5 volts, you can choose those as your "Cal-L" and "Cal-H" points and the unit will be linear between those two settings. If you would like the reverse, then select 50 PSI at 2 volts, and so forth.)*

- Capability to change PID settings to match your system requirements
- Second loop feedback (from a remote sensor) available. Digital units permit user to add, delete, or scale the second loop signal.
- Choices of circuit card mounted or weatherproof factory/field units
- Very wide range of output pressures, including vacuum, absolute, and high pressures.
- Monitor output signal options
- Resistant to vibration and changes in orientation
- Multiple mounting options

Digital Circuit-Card Regulator

The compact Type 3410 (one-loop) and 3420 (two-loop) Circuit-Card Pressure Regulators are perfect for size-conscious OEM's, without sacrificing any of the high-end performance normally associated with full-size I/P's.

The T3400 can be controlled digitally or with industry-standard analog control signals (0-10V or 4-20mA). Industry-standard analog monitor output signals (0-10V or 4-20mA optional) are available for user-monitoring of actual output pressure.

Electrical Connections

- Serial RS-485 Connections
- DC Power
- Optional Monitor Output, Analog Setpoint and Remote Sensor Feedback
- Analog Interface



Keypad/Display Interface

Selection include: input signal, minimum and maximum input signal/output values, units in the display, second loop feedback signal settings, deadband, and proportional gain factor.

A CD with the user manual and a program to configure and control the serial units is included with all digital units, including those with keypad. A small adapter cable is included to permit removal of the keypad to connect to a computer PID settings and other functions not available through the keypad. In effect, this permits serial communications with the keypad removed.

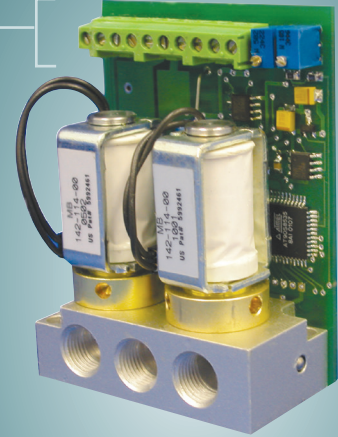

T3410S
Panel Mount

Type 3400 Circuit-Card Regulators



Type 3500 Digital Weatherproof Regulators with Keypad

Dimensional Drawings

DIN Tray Mount

(3100, 3400)

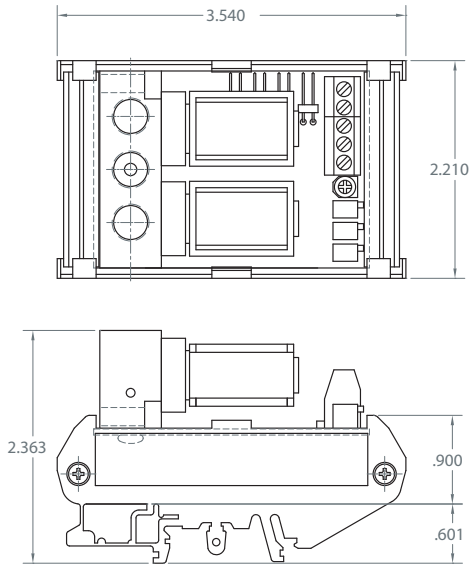

Panel Mount

(3100, 3400)

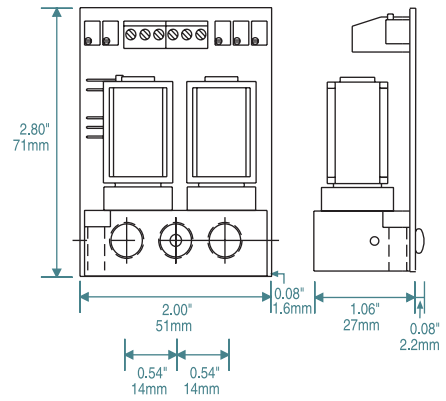

Manifold Mount

(3100, 3400)

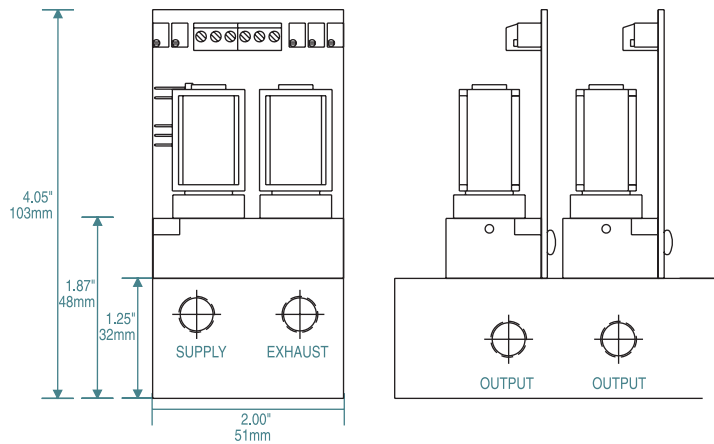

High-Pressure Units (>150 PSIG) T3111, 3410 and

High Pressure (>150 PSIG / 10.3 BAR) units

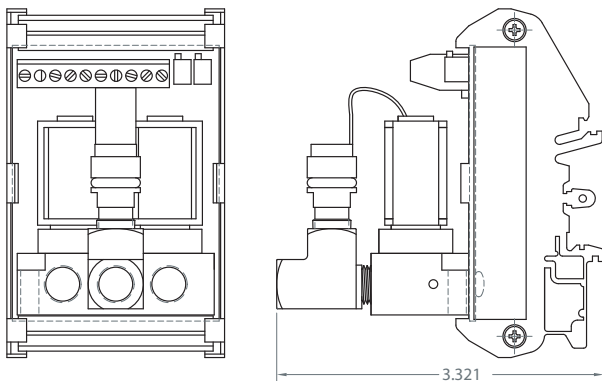

Flush Panel Mount T3100, T3111

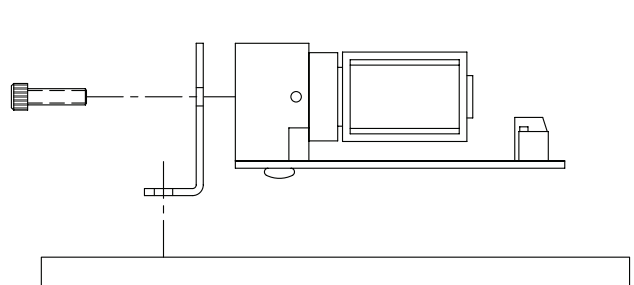

Type 3100 and 3400 Series Manifold Block (7 Station Manifold Shown)

(7 station manifold shown)

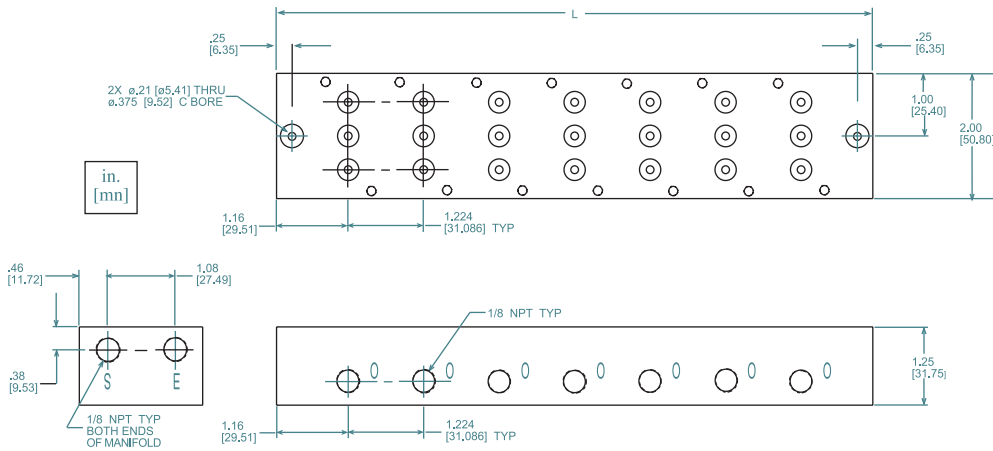

Manifolds are available in 2 to 10 stations.

To calculate the overall length "L" of the manifold use the following formula:

$$L = 2 \times 1.16 + (S - 1) \times 1.224$$

Where S = the number of manifold stations

EXAMPLE: 7 Station Manifold:

$$L = 2 \times 1.16 + (7 - 1) \times 1.224$$

$$L = 9.664 \text{ in. [245.47 mm]}$$

Circuit Board Regulators — Mounting and Packaging

Mounting	Product Configuration	Accessories
DIN Tray	Product mounted in DIN Tray	None
Panel	Product configured for panel mounting	For 'flush' mounting, order Flush Mount Bracket (161-520-00) separately
Multi-Unit Manifold	Product configured for multi-unit manifold mounting	Order Multi-Unit Manifold (350-110-XX) separately. XX = # stations.

Weatherproof Regulator Mounting Options

The Type 3200 and 3500 regulators can be mounted in-line or by brackets which are available separately (DIN-rail bracket — 010-115-000; Panel bracket — 010-135-000). Bracket mounting holes (2 X 8-32 UNC 2B X 0.375"/9.5mm deep minimum) are available on the rear and right faces (when looking at product with IN/OUT flow from left to right) and also on the bottom of the medium-flow booster (shown in diagram).

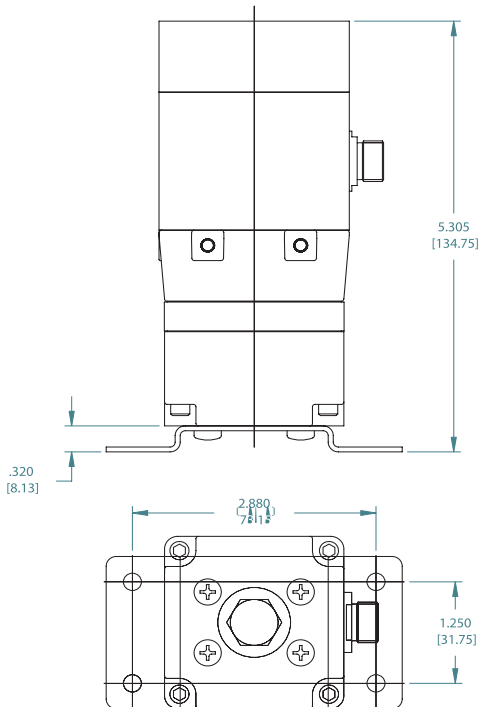

Low-Flow Weatherproof T3210, T3220, T3510,

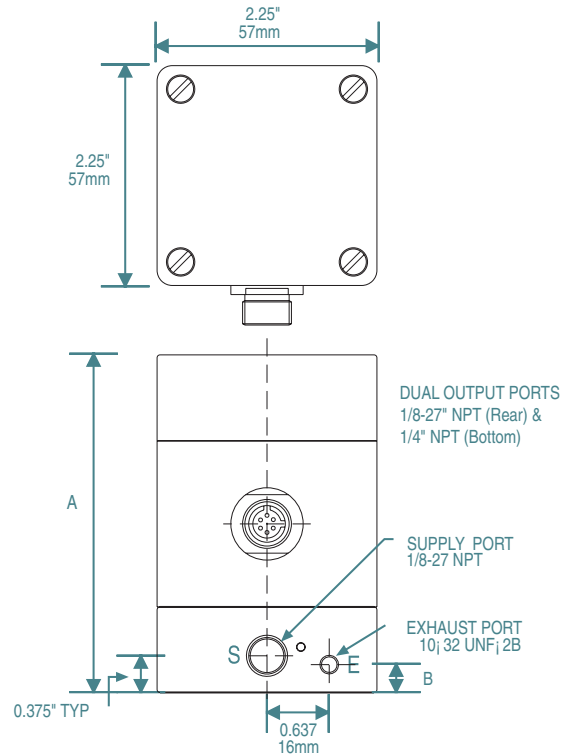

	Pressure Range			
	"A" Dimensions		"B" Dimension	
	Inches	mm	Inches	mm
0-165 PSIG	3.46"	88 mm	0.285"	7.2 mm
0-350 PSIG	3.87"	98.3 mm	0.71"	18.0 mm
0-600 PSIG	5.43"	138 mm	0.71"	18.0 mm

Medium-Flow Weatherproof T3211, T3221, 3511,

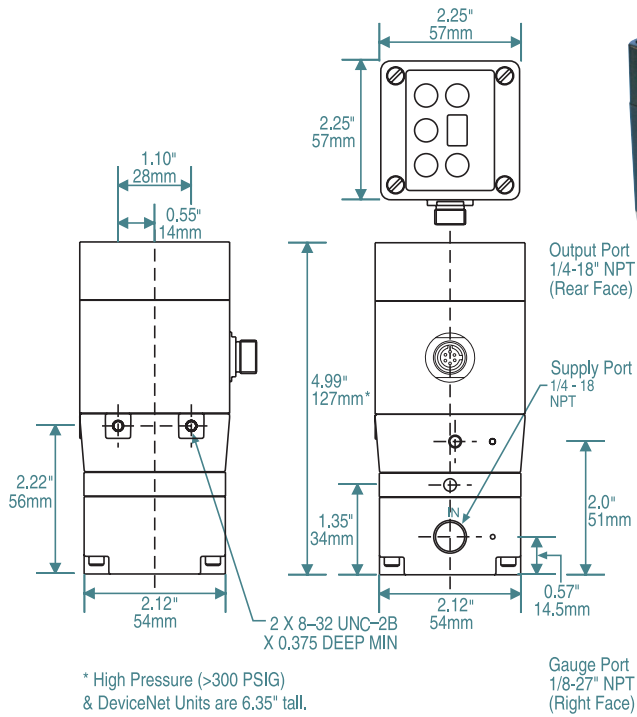

Manifold Mount T3211, T3221, 3511, 3521

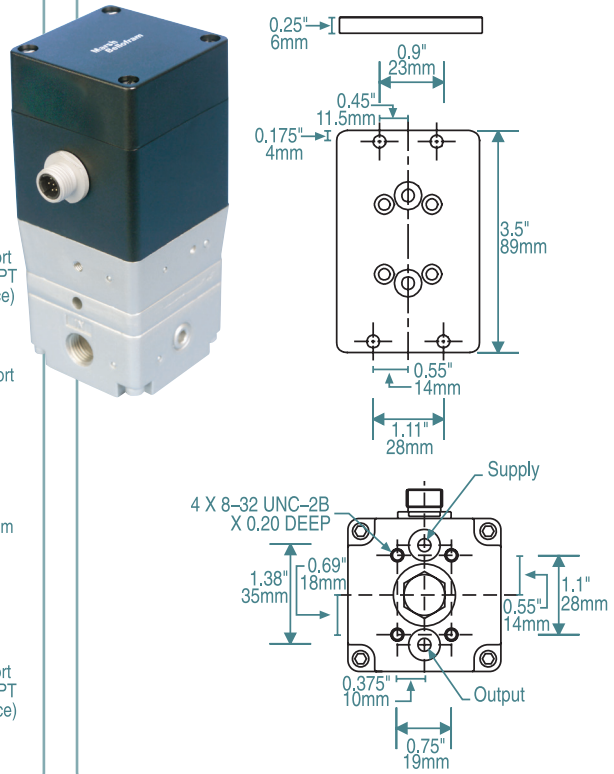

High-Flow Weatherproof T3212, T3222

