



CONOFLOW COMMANDAIRE® POSITIONER GC31 and GC34

The Commandaire® Positioner is a top mounted, integral positioner used with piston or spring and diaphragm actuators. Utilizing a force balance principle this unit provides proportional positioning of an actuator with stroke lengths up to 10". The completely enclosed design eliminates exposed levers or linkages making the Commandaire® Positioner rugged and reliable.

This unit has a single-stage pilot which affords a high degree of stability and excellent positioning accuracy. This high capacity 5 SCFM (0.14 m³/min) at 100 PSI (690

kPa) pilot valve exhausts or feeds supply pressure 20 to 100 PSI (138 to 690 kPa) to the actuator producing fast response. Small changes in the instrument signal are amplified by the high volume pilot assuring fast, stable and precise positioning of the actuator stem.

Available in four versions, the Commandaire® Positioner can be top or bottom loading, direct or reverse acting. Refer to chart below for details.

OPERATIONAL CHARACTERISTICS		GC31	GC32 GC3230	GC33 GC3330	GC34
As Instrument Signal Increases	Positioner Output	Increases	Decreases	Increases	Decreases
	Actuator Stem Moves	Out	In	In	Out
Positioner Output (Loading To Actuator)		Top	Top	Bottom	Bottom
On Air Failure (With Airlock) Actuator Stem Moves		In	In	Out	Out

Adjustable over stroke lengths of 1/4" to 10" (other strokes are available, consult the factory) and instrument spans of 6 to 24 PSI (41 to 166 kPa).

Stable performance is maintained by the force-balance positioning and high capacity pilot. This design makes the Commandaire® Positioner a rugged and reliable unit for today's control instruments.

DIMENSIONAL DATA - ADVERTISING DRAWINGS:

- Fail Safe Schematic: A50-48
- GC31: A50-49
- GC32: A50-50
- GC33: A50-51
- GC34: A50-52

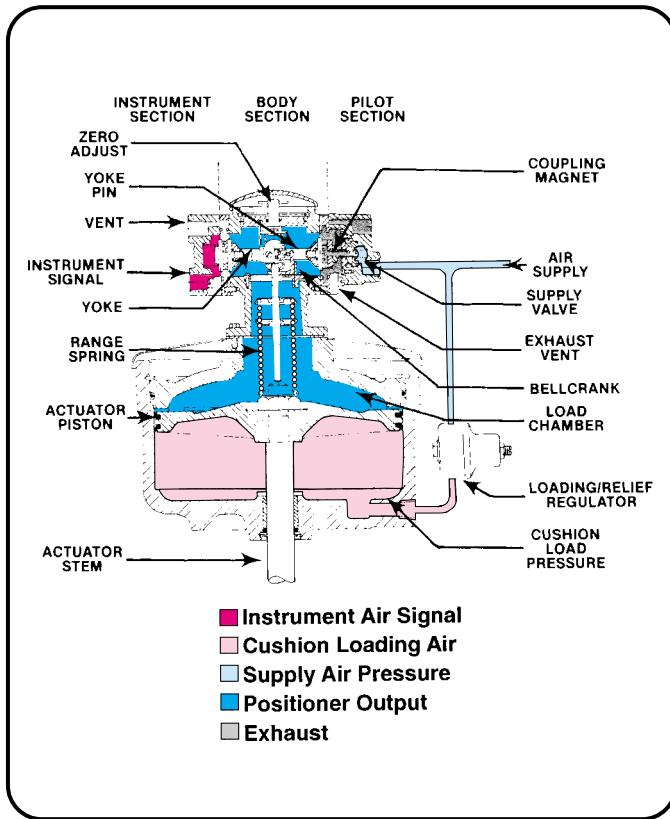

PRINCIPLE OF OPERATION

The Commandaire® Model GC31 positions the actuator by applying sufficient air pressure above the piston to overcome cushion-loading pressure (pressure below piston set by an adjustable pressure reducing/relief type regulator) plus any external forces or load acting on the stem. An increase in air signal creates a force on the instrument diaphragm moving yoke to right, closing exhaust port and opening supply valve. Air flows through supply valve into chamber above the piston and moves it downward. This extends a calibrated range spring causing the bellcrank to pivot counterclockwise, exerting force against the yoke pin, restoring the yoke to normal balanced position. A decrease in instrument air pressure reverses the procedure, closing supply valve and opening exhaust port venting to atmosphere excess air pressure above the actuator piston.

SPECIFICATIONS

Supply Pressure Effect: Less than 0.15% per PSI

Power Amplification - (Proportional Band): Less than 5.0% deviation in signal or stroke produces full output pressure change

Ambient Temperature Range: -20°F to +150°F (-29°C to +66°C)

Flow Capacity (Dynamic): Up to 5.0 SCFM (0.14 m³/min) in either direction with a 100 PSI (690 kPa) supply

Air Consumption (Static): 0.3 SCFM at 40 PSI supply
(0.008 m³/min at 276 kPa)

Air Supply: 20 PSI to 100 PSI (138 to 690 kPa)

Controller Signal: All standard spans and split ranges available.

Zero Suppression: 0 to 18 PSI (0 to 124 kPa)

Control Actions: Direct or reverse, top or bottom loading

Actuator Travels: 1/4" to 10" (6.35 to 254 mm)

Connections: 1/4" NPT

Adjustment: Zero adjust is external and can be made without tools.

Mounting: Mounted integrally to top of cylinder or spring and diaphragm actuator with 2-1/4" dimension between positioner mounting flange and actuator stem in retracted position.

Weight: Approximate Shipping Weight: 2-3/4 lbs. (1.25 Kg)

NOTE: Specifications are typical values based on the use of a Conoflow GB50 Series Actuator. Use of other actuators may affect performance.

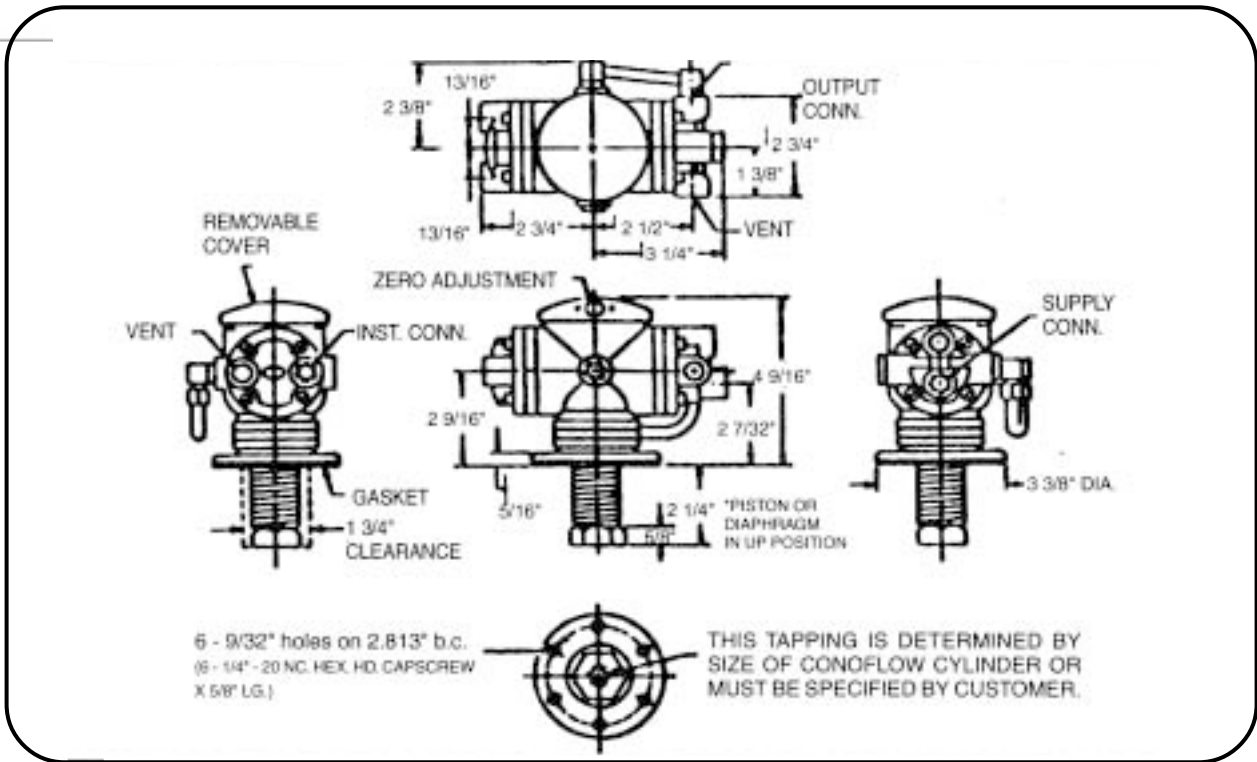

For Certified Dimensional Data, refer to Drawings A50-49 (GC31)

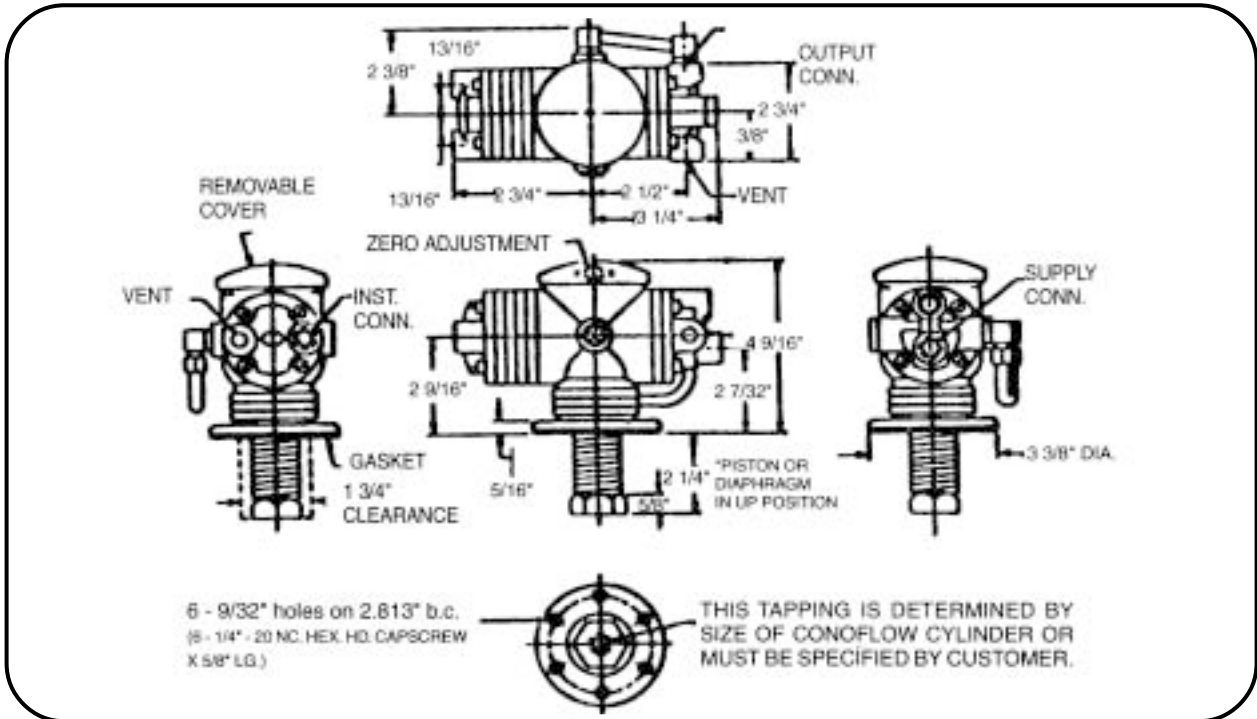

For Certified Dimensional Data, refer to Drawings A50-50 (GC32)

- NOTES:**
1. All connections are 1/4" NPT unless otherwise noted.
 2. When ordering, specify model, range and stroke.
 3. For piping schematics See A50-48.
 4. Vents can be tapped 1/4" NPT for Gas Service.

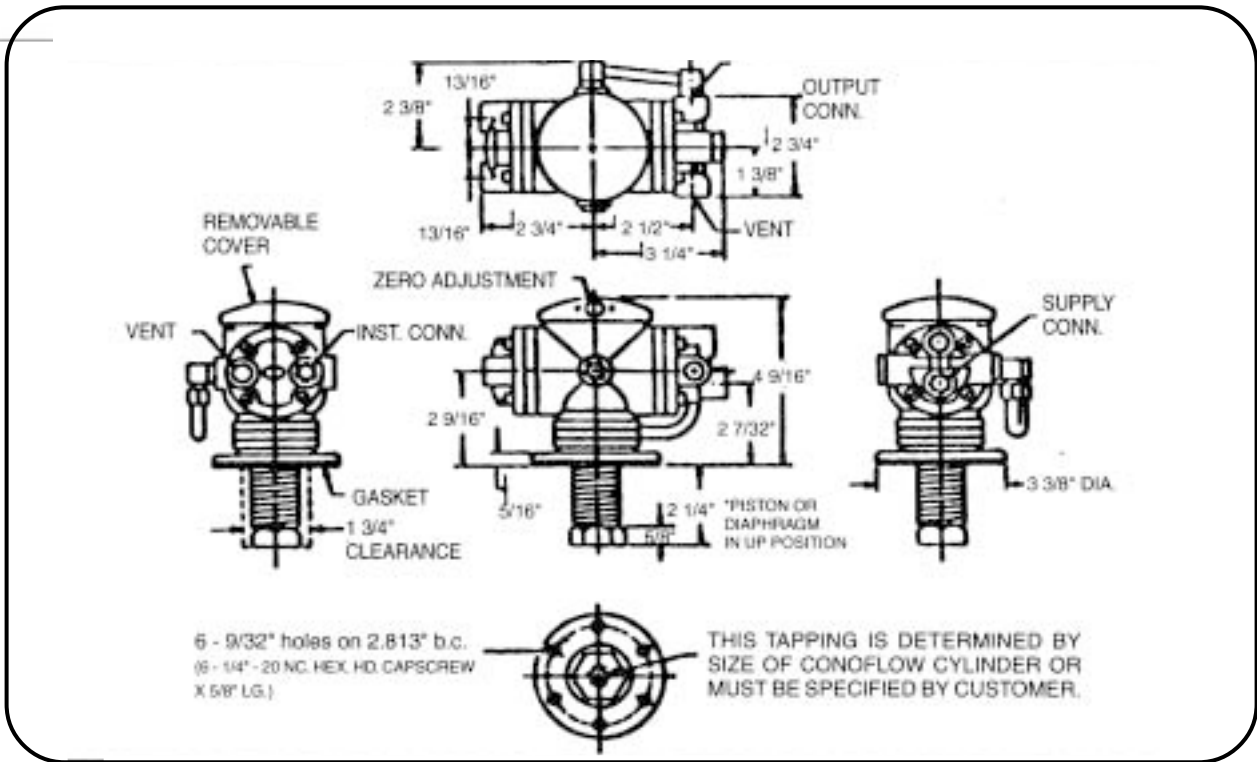

For Certified Dimensional Data, refer to Drawings A50-49 (GC31)

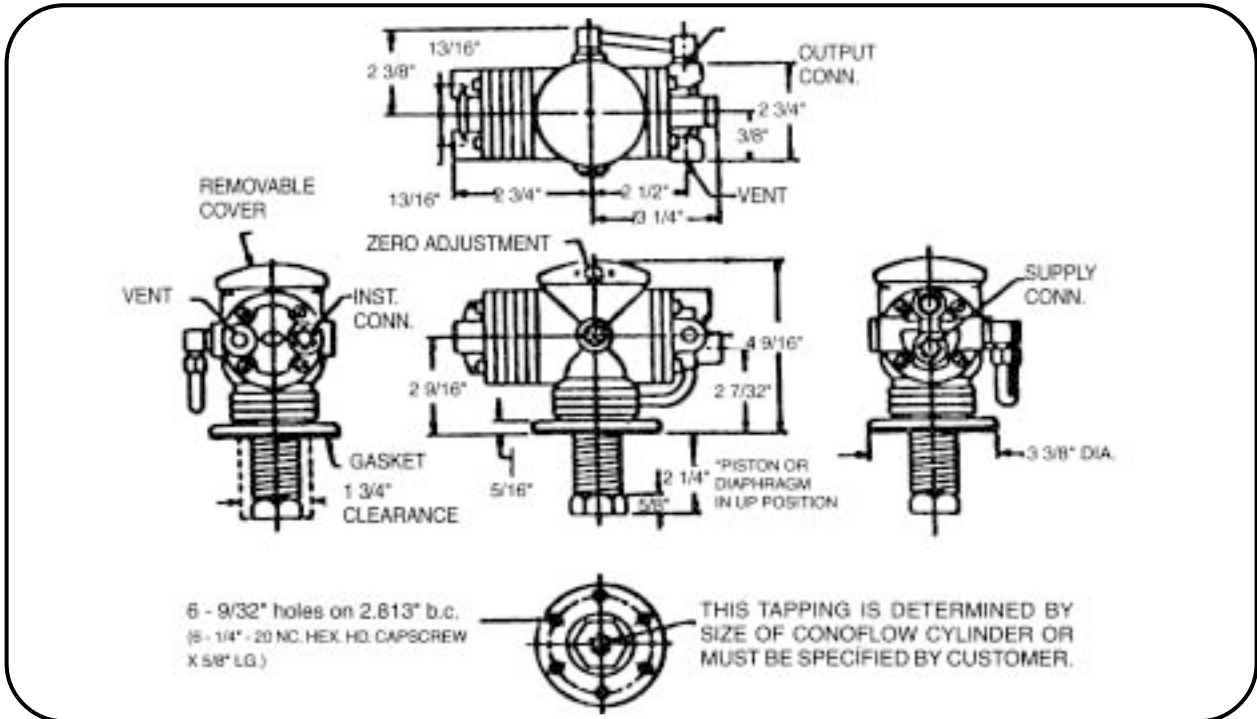

For Certified Dimensional Data, refer to Drawings A50-50 (GC32)

- NOTES:**
1. All connections are 1/4" NPT unless otherwise noted.
 2. When ordering, specify model, range and stroke.
 3. For piping schematics See A50-48.
 4. Vents can be tapped 1/4" NPT for Gas Service.

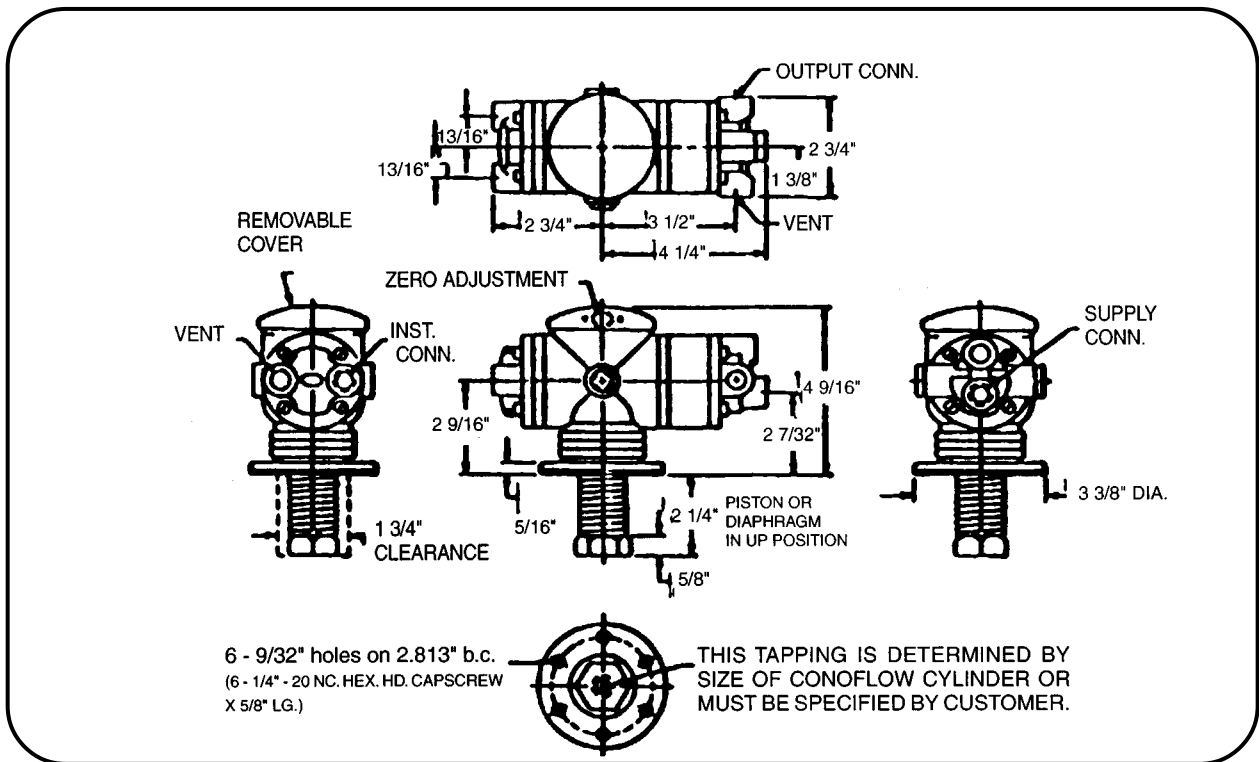

For Certified Dimensional Data, refer to Drawings A50-50 (GC33)

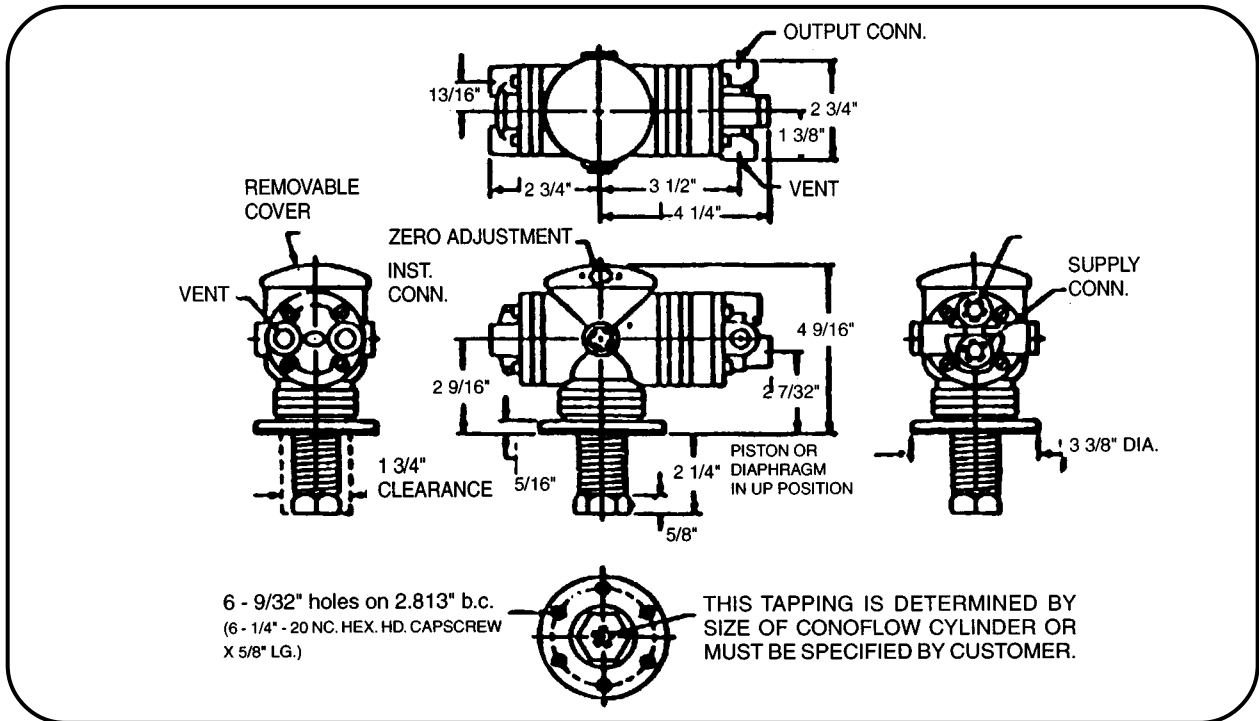

For Certified Dimensional Data, refer to Drawings A50-52 (GC34)

- NOTES:**
1. All connections are 1/4" NPT unless otherwise noted.
 2. When ordering, specify model, range and stroke.
 3. For piping schematics See A50-48.
 4. Vents can be tapped 1/4" NPT for Gas Service.

Mountain Controls



COPPUS®
Air Movers



Portable Ventilators
Fans & Blowers
Welding Fume Exhausters
Duct

Ball Valves and Actuators
Spring Return Electric Actuators
Resilient Seated Butterfly Valves
High Performance Butterfly Valves



MARSH®

Pressure Gauges
Thermometers
Needle Valves and Diaphragm Seals



BELLOFRAM®
Precision Controls

Precision Air Regulators
Air, Gas, Steam & Water Regulators
Vacuum and Backpressure Regulators
I/P and E/P Transducers



Marshalltown-Tempco

Temperature Indicators
Temperature Switches
Capillary Bulb Type



MOORE INDUSTRIES
WORLDWIDE

Process Controllers
Multi-Loop
Process Indicators with Switches



POWERS
PROCESS CONTROLS
Quality...Our Commitment

Control Valves – Globe Type
Temperature Regulators
Self Contained
Temperature Controllers



RCS

Electric Actuators
Modulating Controllers
Spring Return – SURE
Mounting to your valves.



SVF
Flow Controls, Inc.

Ball Valves – 3-piece
Pneumatic Actuators
Electric Actuators
Specialty Valves



Solenoid Valves
Water – Air – Hot Water – Steam
Pilot Valves



Valve
Actuator Mounting

We stock electric actuators and can provide the mounting and testing to the valve of your choice

Mountain Controls

Salt Lake City, UT 84109
Phone: 801-487-8795

Seattle, WA 98125
Phone: 206-316-2330

www.mountaincontrols.com

info@mountaincontrols.com